

## Fabricated Steel Elevator Bucket Carbon Steel/Stainless Steel

### FEATURES

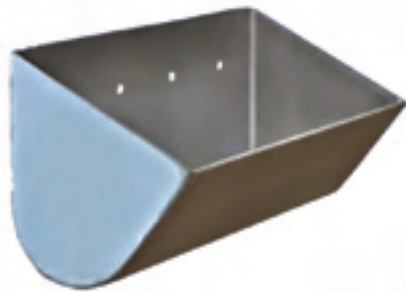

- Manufactured by folding, punching, and welding.
- Well suited for high temperature applications or when extremely sharp products are carried in bucket elevators.
- Allow almost an infinite number of bucket designs to be realized, these could include thicker wear resistant leading edges, specialized bucket shapes and sizes, etc.

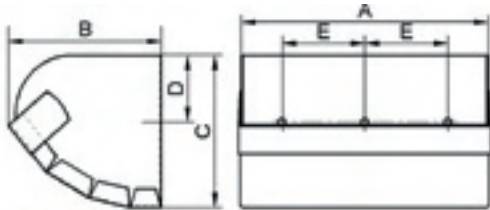

### Usage Recommendations

- Minimum bucket spacing: bucket depth "C" +10mm
- For engineering purpose, we recommend using "L" for usable capacity.
- Mounting holes can be customised on request
- Venting holes are available in 5 patterns on request

### TECHNICAL SPECIFICATIONS

Model	Bucket Dimension (mm)			Mounting Holes (mm)				Capacity (L)
	Length A	Proj. B	Depth C	Center to Center E	Number of Holes	Hole Diameter	Distance Down D	
FSD3016	300	165	155	86	4	6.5	52	4.65
FSD3522	355	220	205	76	5	8	90	9.35
FSD4022	405	220	205	73	6	8	90	10.67
FSD4522	455	220	205	79	6	8	90	11.98

Note: Customized bucket shapes and sizes are available on request.

## Elevator Buckets

Over 12 different bucket styles available for agricultural and industrial applications.

A direct replacement for many other international brands.

Unique bucket design with multiple patents.

Our buckets are well regarded worldwide for their high quality to price ratio.



### BUCKET MATERIAL OPTIONS

Material	Mild Steel	Stainless	HDPE	Nylon 6	Reinforced Nylon	PU
Cost	■■■	■■■■	■	■■■	■■■■	■■■■
Wear Resistance	■■■	■■■■	■	■■■	■■■■	■■■■
Impact Resistance	■■■	■■■	■	■■■	■■■■	■■■
FDA Food Approved	X	√	√	√	√	X
Max Temp °C Continuous	180+	250+	70	100	110	60
Max Temp °C Peak	220	400	80	120	130	70

**HDPE:** Tough and flexible, suitable for handling grains, foodstuffs, and other products with no sharp edges and material that has a bulk density of less than 1g/cm<sup>3</sup>.

**Nylon:** High impact and abrasion resistance, better heat resistance and are well suited for handling hot, abrasive and sticky products.

**PU:** Extremely abrasion resistance, tough and flexible, and are suitable for handling sharp, cutting and sticky products.

**Mild Steel:** General purpose, long life, well suited to agricultural and industrial products.

**Stainless Steel:** Food grade, corrosive resistance, suitable for food and high temperature applications.

### MEASURE AN ELEVATOR BUCKET

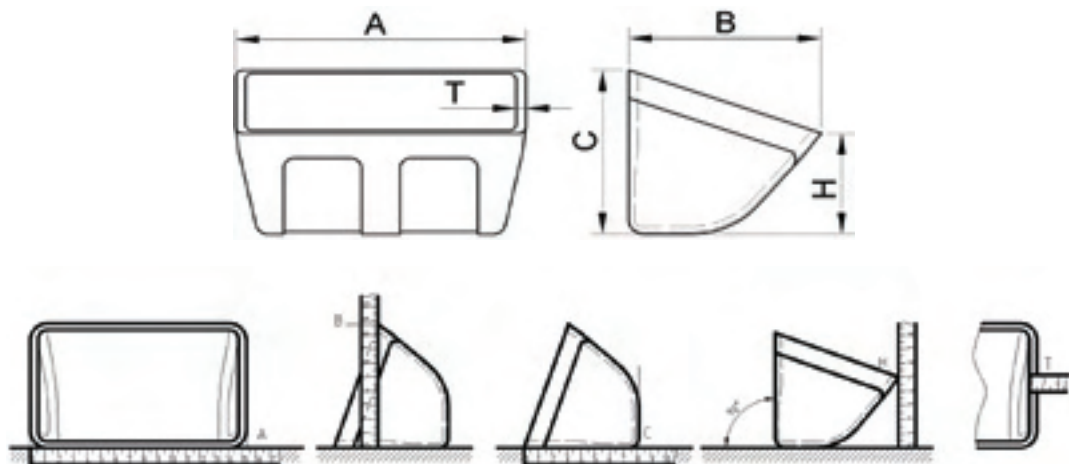

## ELEVATOR BUCKET VENTING

Bucket with venting holes can improve the efficiency of some bucket elevators when handling certain products. On dense materials such as flour, meals, and mash feeds, the vents allow air to escape through the cup as it fills, which permits the cup to fill more completely. During discharge, air can return through the cups as it empties, thus preventing a vacuum that could hold some of the products in the cup and cause backlegging.

On extremely light materials such as alfalfa meal, screenings and bran, a vented bucket not only minimizes blowing of the product during loading and discharge, but also reduces air turbulence in the leg as the bucket travels empty down the return side of the elevator. A reduction in air currents minimizes the vacuum which can draw a light product through the down leg and back to the boot.

Four standard patterns air available. Customised patterns are available upon request.

### Venting Options

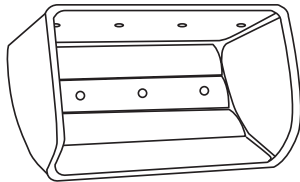

**Vent Pattern 1**

One row of 6mm or 8mm holes in body with same hole center and number of holes as mounting holes in back.

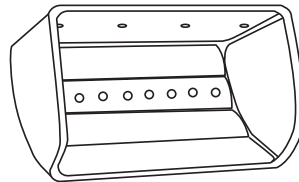

**Vent Pattern 2**

One row of 6mm or 8mm holes in body on 25mm centers.

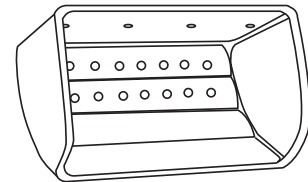

**Vent Pattern 3**

Two rows of 6mm or 8mm holes in body on 25mm centers.

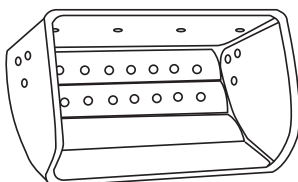

**Vent Pattern 4**

Two rows of 6mm or 8mm holes in body on 25mm centers, three holes of 6mm or 8mm on each side.

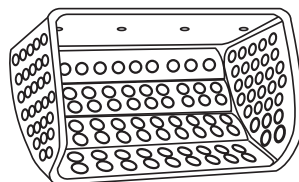

**Custom Vent**

Vented as required.

